

belgian
design

—

made in
Belgium



Nathalie Dewez Lighting

Since studying interior design at ENSAV La Cambre in Brussels, Nathalie Dewez has been drawn to experiment as much with spatial arrangement as she has with the creation of objects. Dewez's designs typically animate their surrounding space in a highly considered manner. Particularly in her lighting elements, a sense of delicate balance and gentle movement elevates quite minimal forms from mere functionality into something akin to kinetic sculpture.

Dewez's designs for lighting and furniture elements often emerge in response to specific commissions, or from collaborating with architectural bureaux. Working directly on sites ranging from the domestic, through retail, hospitality and major museums, Dewez has produced custom designs that respond to the requirements of both particular spaces and the functions they serve. This first-hand experience of marrying formal, technical and atmospheric requirements feeds back into her products for brands including Ligne Roset, Hermès and Habitat.

Significant private commissions include the creation of a minimal yet spectacular pendant lamp for the atrium of the MUDAM Museum of Modern Art in Luxemburg. Over three metres in diameter, the fabric-covered inflated globe comprises three concentric spheres and balances at one end of a long axis gently secured by a counterweight. For the Queen Elizabeth Music Chapel in Belgium, Dewez designed subtly rotating light elements to create a welcoming environment in a facility for world-leading young musicians.

When Dandoy – a venerable and much-loved bakery in Brussels – underwent a re-design, Dewez created contemporary lighting elements that conveyed a certain classicism in their choice of simple, high quality materials. Each element performed a double function of illumination and reflection, drawing attention back to the store's product.

The lamps gathered here are the fruit of a self-initiated project between Dewez and BIS Lighting : a Brussels-based manufacturer with which the designer has previously worked on custom and one-off projects.

In the Balance lamp we find Dewez working inventively with what might otherwise be seen as technological restrictions. The counterweight for this minimal, serpentine table light conceals the transformer box needed for the LEDs. Ellipse is a suspended light that gives a soft glow from the indirect light reflected within its asymmetrically folded elliptical form.

The Still pendant moves like a mobile – a balancing metal rod with a light at one end that shifts in the breeze and which can be tilted by adjusting its counterweight. Prism is a spectacular yet lightweight suspended sculpture formed from angled metal rods, casting a delicate pattern onto the surrounding walls.

Some two metres high, the slim, elegant Danse quivers like an illuminated reed on a rocking, weighted, hemispheric base. Smoke & Mirrors beguiles with light radiating from the edges of a wide, slim, wall-mounted mirror.

The forms are elaborations of hardworking designs that have become part of Dewez's repertoire. These are the Belgian designer's tried and tested favourites, manufactured in her home country using durable materials.



Prism

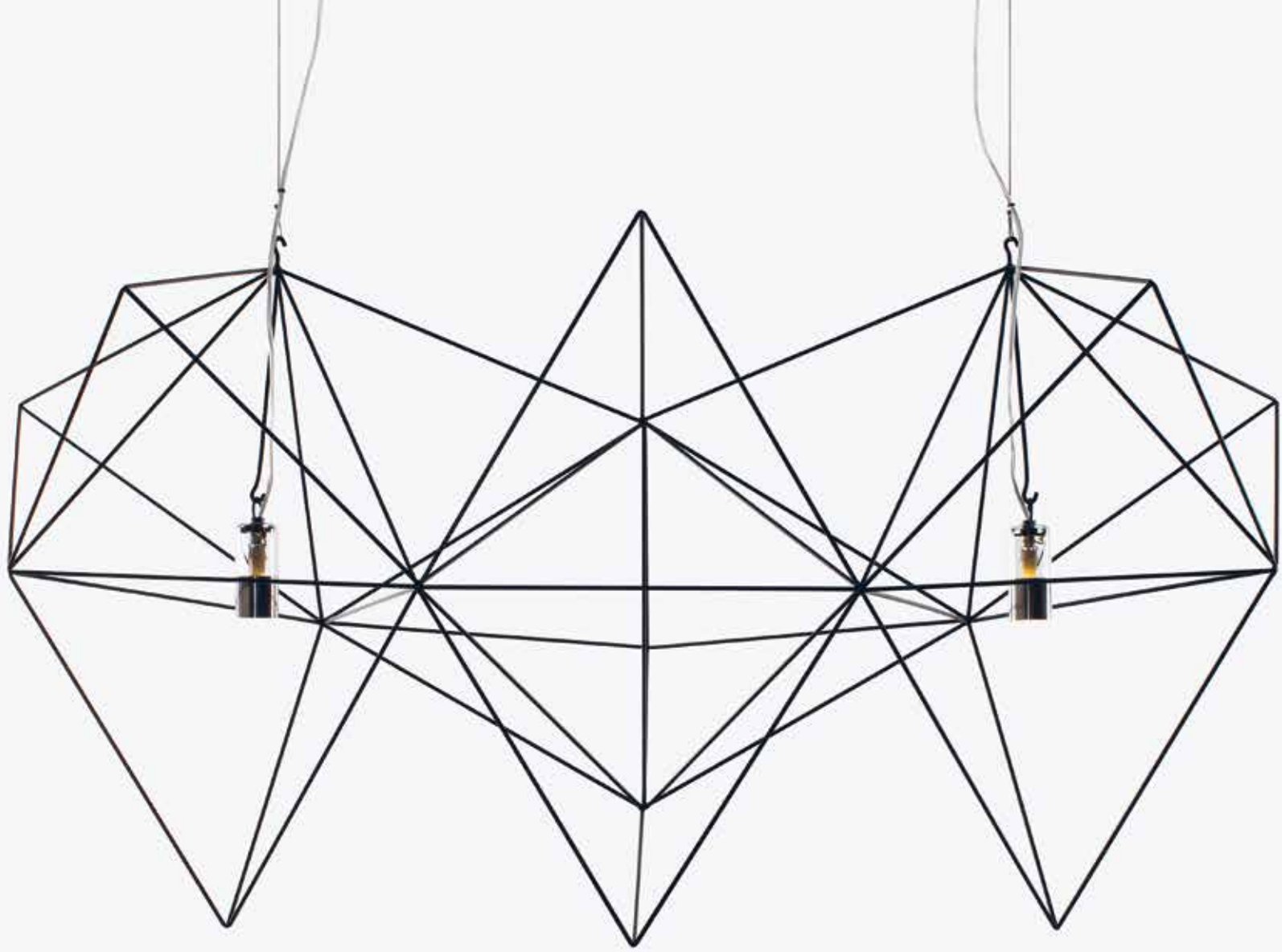

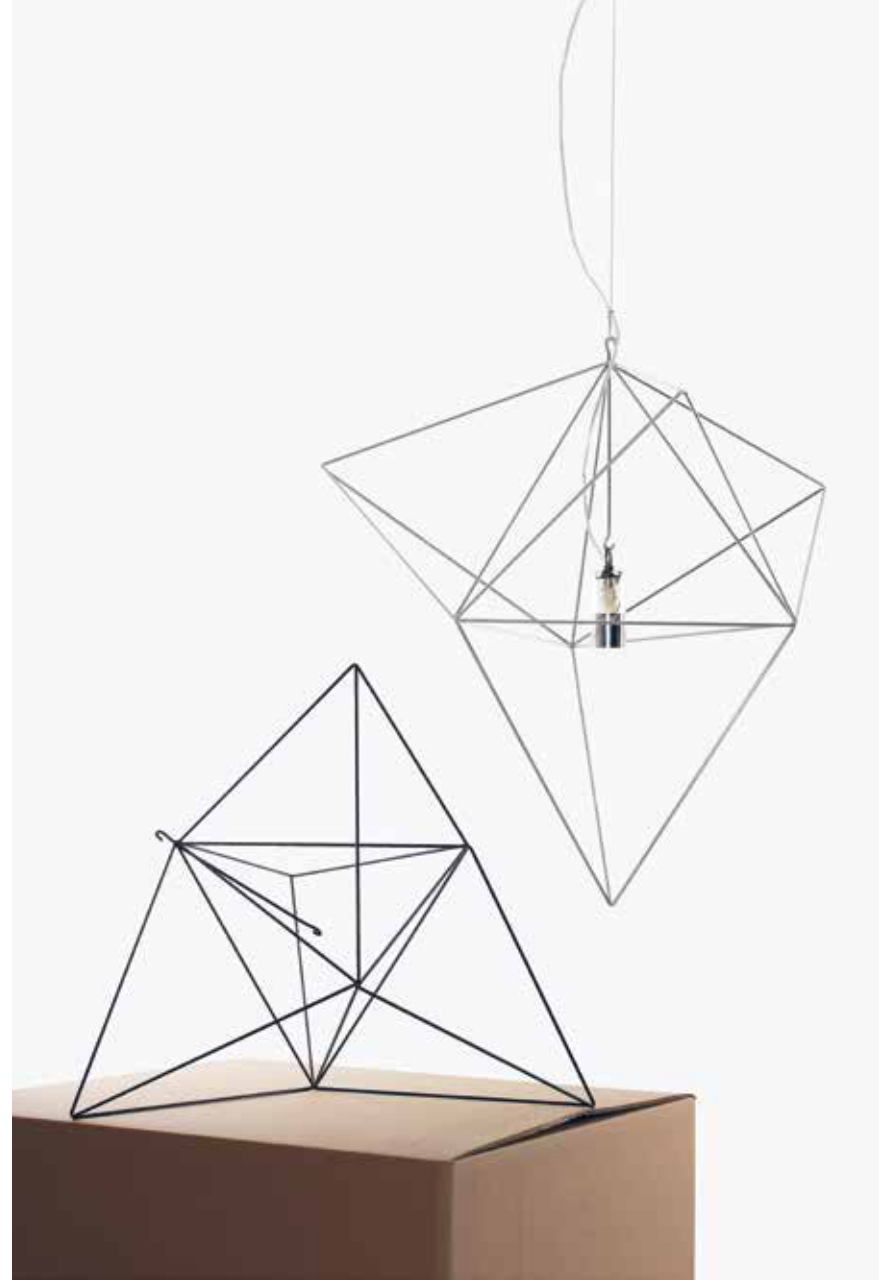

PRISM

—
Hand-crafted steel structure pendant

Lamp holder in glass & aluminium
Canopy in same color as lamp

Light source :
230V – driver built-in
G9 Power LED (included)
Warm white : 2800K – CRI > 80
Dimmable : yes

Prism Small

W78 x H76,5 x D78 cm
1 lamp – 3W – 200lm

Prism Large

W123 x H76,5 x D78 cm
2 lamps – 6W – 400lm

Suspension cable : 0 – 250 cm
Adjustable at installation

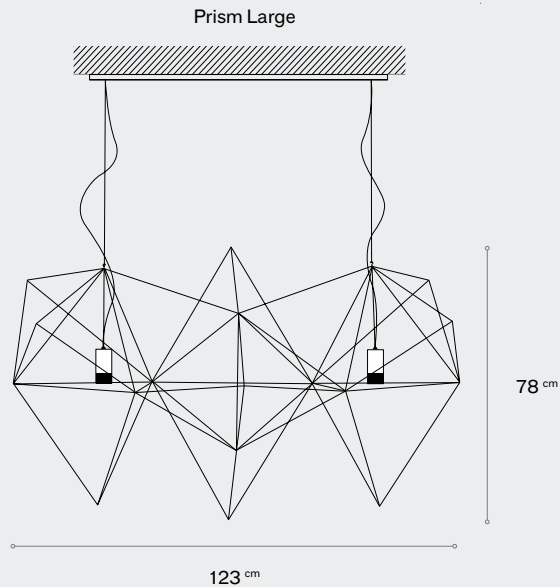
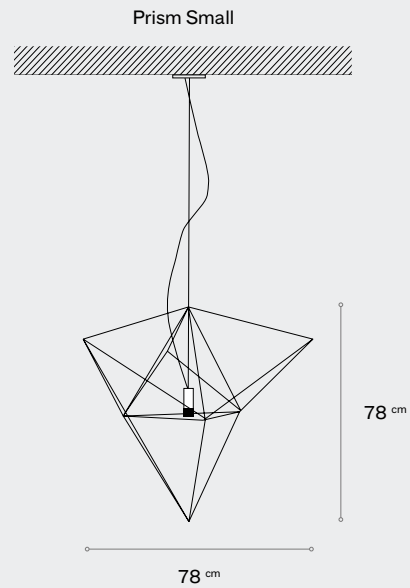

BASE COLOR

Powder coated – matt



RAL 9005

SPECIAL COLORS

Powder coated



Metallic

(other colors on request)

The Prism pendant lamp was designed to dress a light source placed in the center of it, and give it an echo. The sculptural composition of facets, lines and shadows surrounding the central light source gives it more scope and emphasis while keeping a certain lightness and transparency in space. The complex hand-made structure acts as a frame in three dimensions, highlighting the light without cluttering the visual field.

Balance







BALANCE

—
*Aluminium & Steel self-balancing
table lamp*

Light source :
230V – driver included
Built-in LED strip
7,2W – 450lm
Warm white : 2700K – CRI > 80
Dimmable : no

W100 x H85 x D4 cm
Power cable : 2,5m
with foot switch

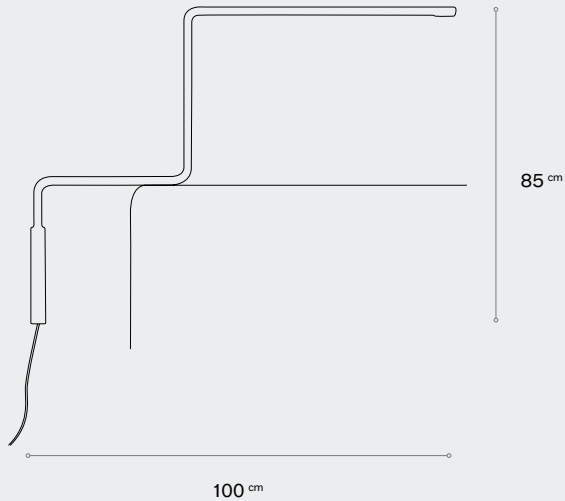

BASE COLOR

Powder coated – matt



RAL 2004



RAL 9005



RAL 1023

Special finishing



Chrome

(other colors on request)

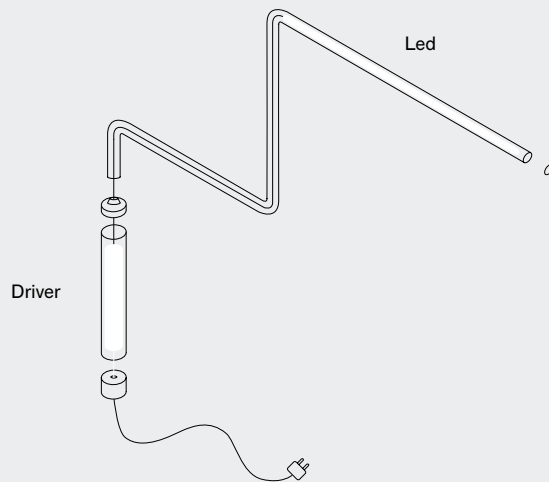

The concept of the Balance desk lamp was born out of a technical constraint. By using the driver - inevitable in led lighting - as a counter weight in the lower half, the technical solution became the design of the product. The result: a meandering, minimalistic and elegant self-balancing reading lamp without the need of any obstructive base or inflexible fastening system. The metal tube welcoming the electric equipment presents a very simple visual reading of the lamp which allows its understanding and its immediate apprehension.

Ellipse





ELLIPSE

—
Folded elliptical aluminium sheet pendant

Canopy in same color as lamp

Light source :

230 V – Osram TL5 (included)

Warm white – 3000 K – CRI > 90

Ellipse Small

W134 x H28 x D 43 cm

28 W – 2600 lm – dimmable

54 W – 4450 lm – not dimmable

Ellipse Large

W164 x H40 x D 60 cm

35 W – 3300 lm – dimmable

49 W – 4300 lm – non dimmable

Suspension cable : 40 – 250 cm

Adjustable at installation

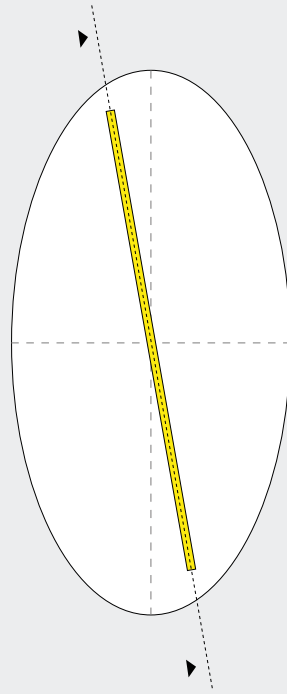

BASE COLOR

Powder coated – matt

Mono-color



RAL 9016

Bi-color



RAL 9016



RAL 2002



RAL 9016



RAL5019

Special finishing



Brass

(other colors on request)

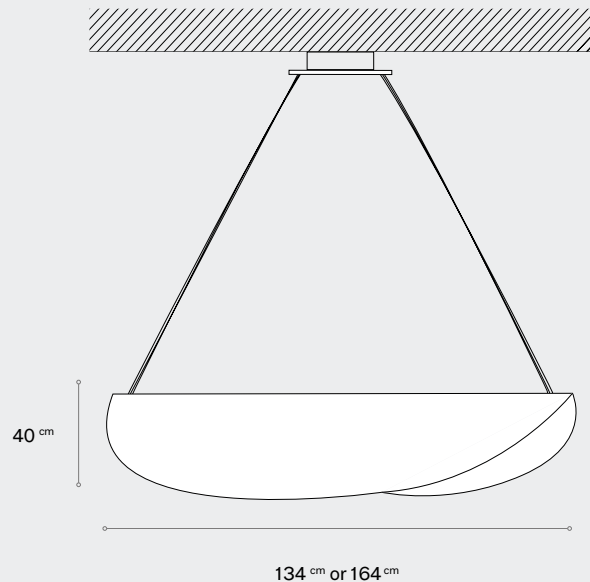

Inspired by the work of American artist Ellsworth Kelly, the Ellipse pendant lamp was developed to illuminate a table, a desk, or any surface. Elegantly hanging from 2 metal wires, its shade is an elliptical aluminium sheet folded asymmetrically. The resulting balanced mixture of focused downward light and diffuse sideward light, is easy on the eye, and makes this centerpiece applicable in many different settings.

Still



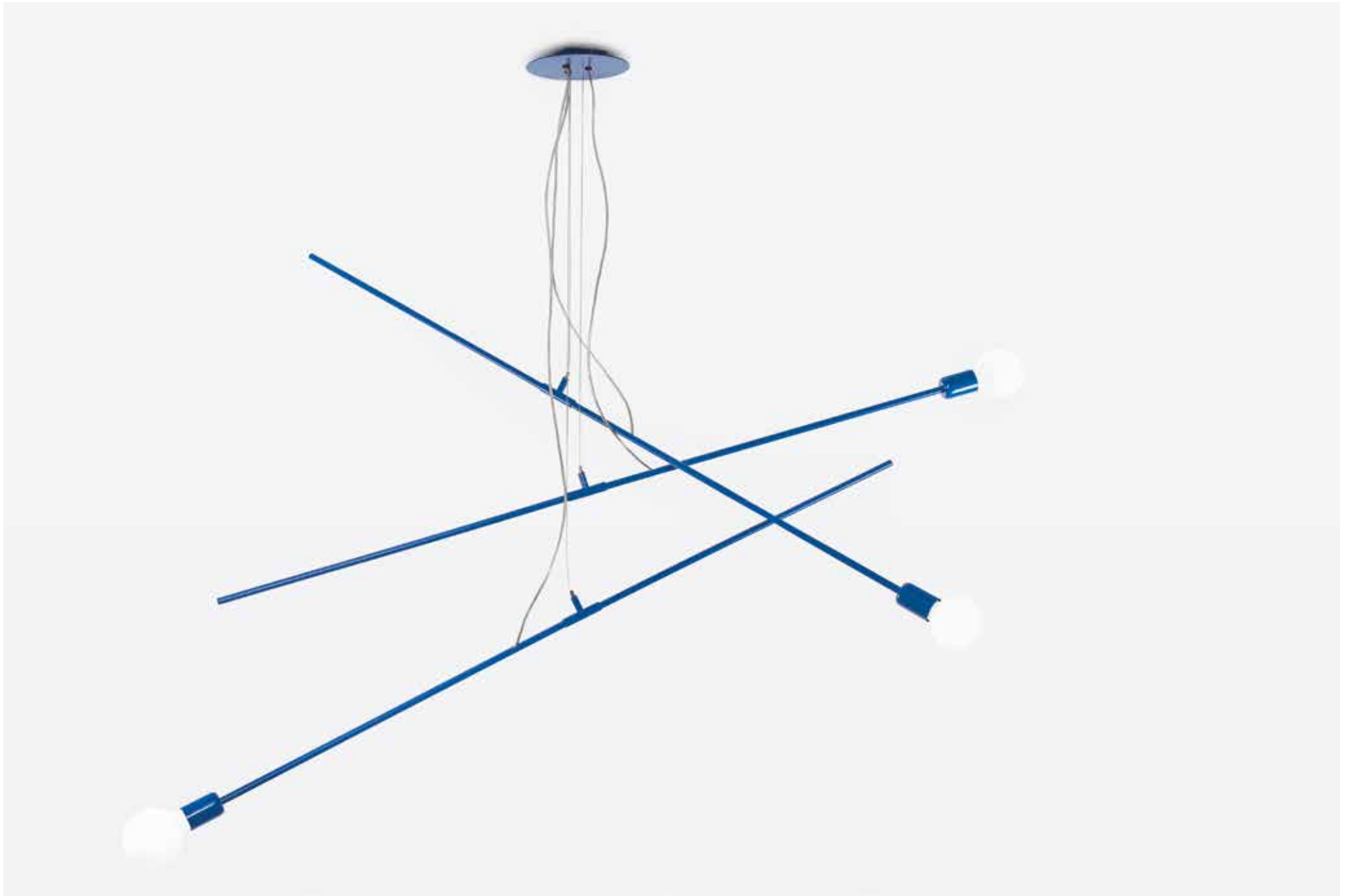

STILL

Aluminium & steel dynamic pendant

Canopy in same color as lamp

Light source :
230V – driver built-in
E27 opal LED filament bulb
(included)
Extra Warm white – 2500K
CRI > 90
Dimmable : yes

Still Small 150 cm

- Single – 5,5W – 420 lm
- Triple – 16,5W – 1260 lm

Still Large 240 cm

- Single – 6,5W – 470 lm
- Triple – 19,5W – 1410 lm

Suspension cable : 0 – 250 cm
Adjustable at installation

BASE COLOR

Powder coated – matt



RAL 9005

RAL 1023



RAL 2002

RAL 5005

Special finishing



Chrome

(other colors on request)

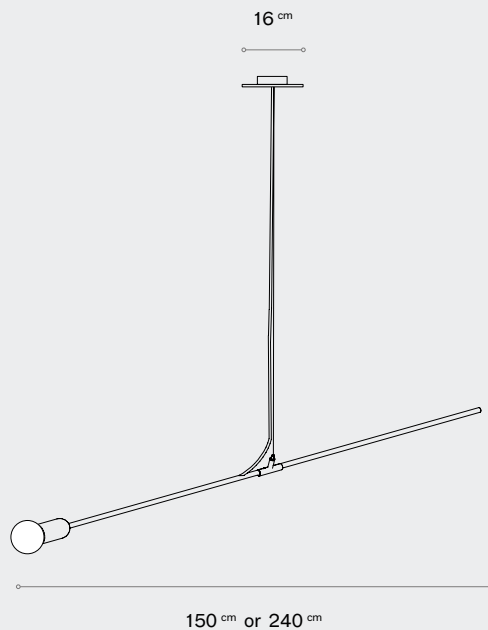
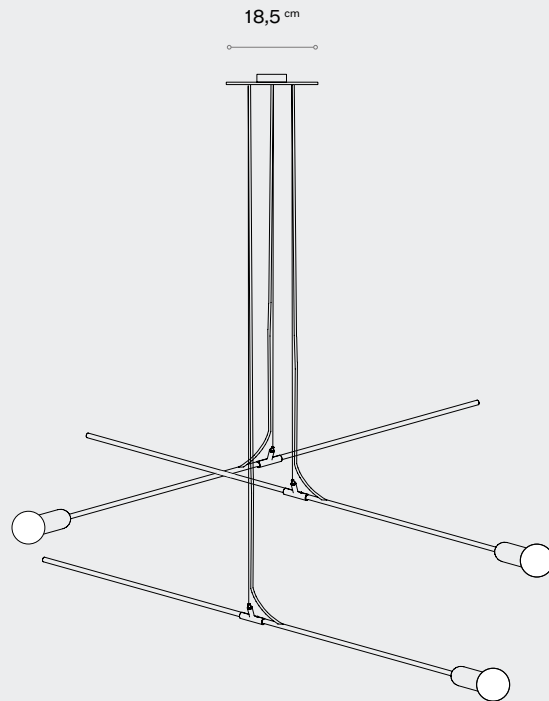

The Still lamp works as a mobile. The Still pendant lamp has the particularity of having the light source off-center from its point of suspension, creating an ever-changing elegant dynamic. Due to its dimension she dresses and emphasizes a space and its size, without the clutter. A puff of wind would have it slightly moving. The Still is never completely still.

Danse





DANCE

Carbon fiber floor standing luminaire

Tubular frosted plexiglass shade
Massive steel base – diam 20 cm

Light source :
230 V – driver built-in
G9 Power LED (included)
1,8 W – 200 lm
Warm white : 2700K – CRI > 80
Dimmable : no

Danse Small – 170 cm
Danse Medium – 200 cm
Danse Large – 230 cm

Power cable : 2,5m with foot switch

BASE COLOR

Powder coated – matt



RAL 9005

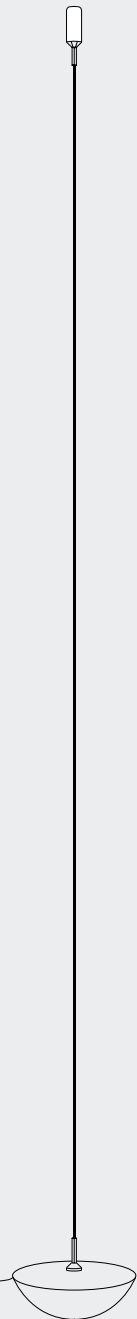

This model of elegant simplicity plays with the surrounding room without invading in, reminiscing an illuminated reed. The combination of a massive base and flexible fiberglass stem creates a physics-defying masterpiece, accentuating the verticality of a room. Especially chic when grouped in places with high ceilings.

Smoke & mirrors





SMOKE& MIRROR

Anodized aluminium mirror wall lamp

Dual effect mirrors

Light source :

230V – driver included

Built-in Osram LED strips

35 W – 3000lm

Warm white – 2700 K – CRI > 80

Dimmable : yes

Horizontal

W160 x H50 x D9 cm

W230 x H25 x D9 cm

Vertical

W45 x H160 x D10 cm

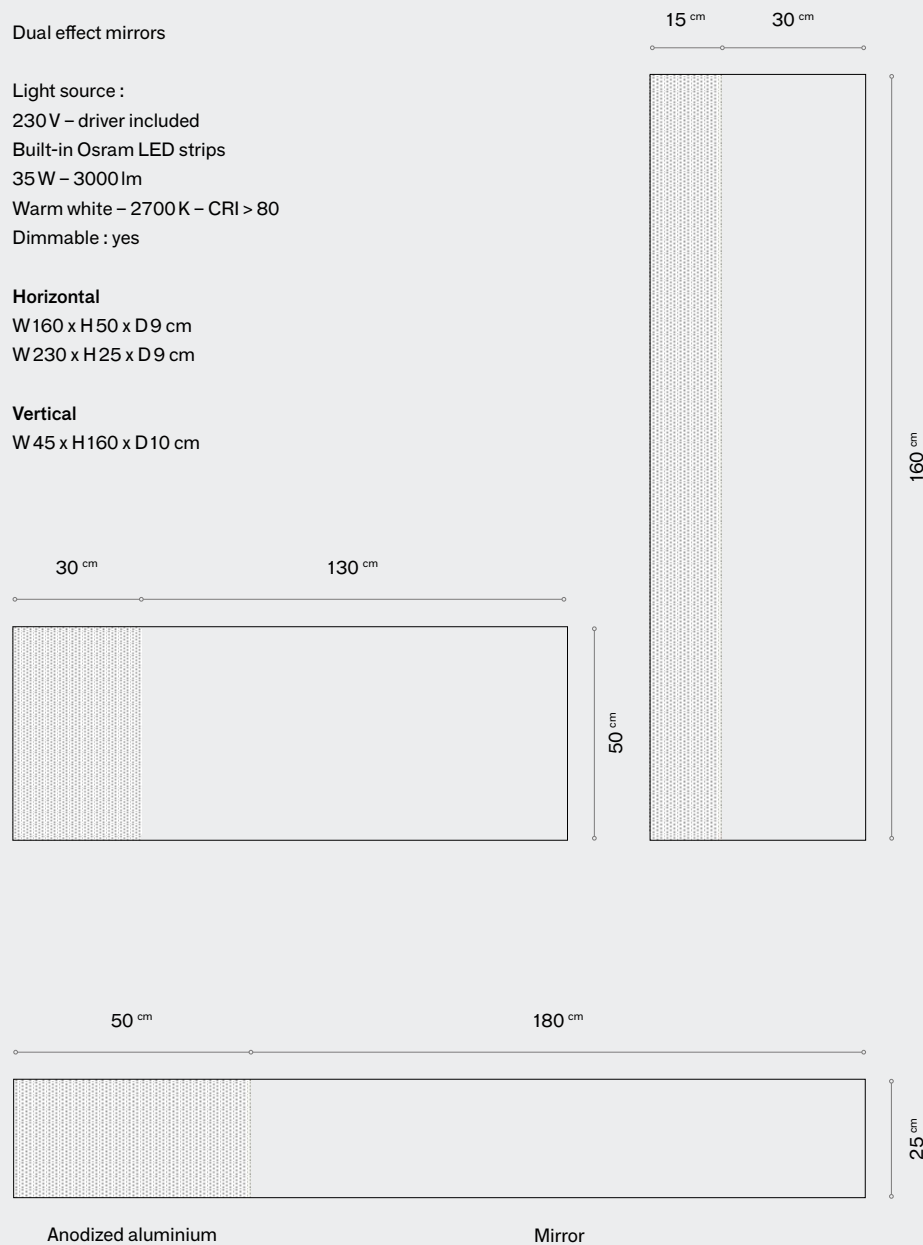

You can find three sizes in the series of backlit mirrors Smoke & Mirrors. This model combines lighting and mirror. The indirect light wraps the subject in a subtle and soft glow, while the combination of plain mirror and silvered ocean glass adds a unique dynamic to it. Functionality meets artistry.



BIS Lighting NV
Jetsesteenweg 409
1090 Jette - Belgium

—
sales@bislighting.be

—
T. +32 2 421 39 70
F. +32 2 425 95 04

—
www.ndlighting.be

All rights are reserved
© Nathalie Dewez & Bis Lighting Edition
Photos by Stijn Bollaert / Julien Renault
Graphic Design by facetofacedesign.com



